



9150 VEHICULAR SLIDE GATE OPERATOR



entrapment
prevention system
reverses gate on contact



fail-safe release
Never be locked out (or in)
of your property



built in
power and reset switches



partial open
allows long gates to open 14
feet for automobile traffic, or
opens gate fully for large trucks
or oversized vans

- Electronic magnetic limits eliminate old style mechanical switches that can wear out, break, or fail
- Automatic self-setting limits mean no limit switch adjustments – ever
- Safety – built-in mechanical and electronic reverse system
- Special anti-tailgating feature helps to reduce unauthorized vehicle access
- Advanced microprocessor control board features programming switches to set the mode of operation required and has ports for DKS plug-in loop detectors to simplify wiring
- Convenience outlets for accessory transformers
- G90 galvanized steel frame prevents rusting
- This operator meets or exceeds the requirements of the UL 325 and UL 991 safety standards and is ETL Listed
- 5-year limited warranty

FEATURES

ACCESS CONTROL SOLUTIONS

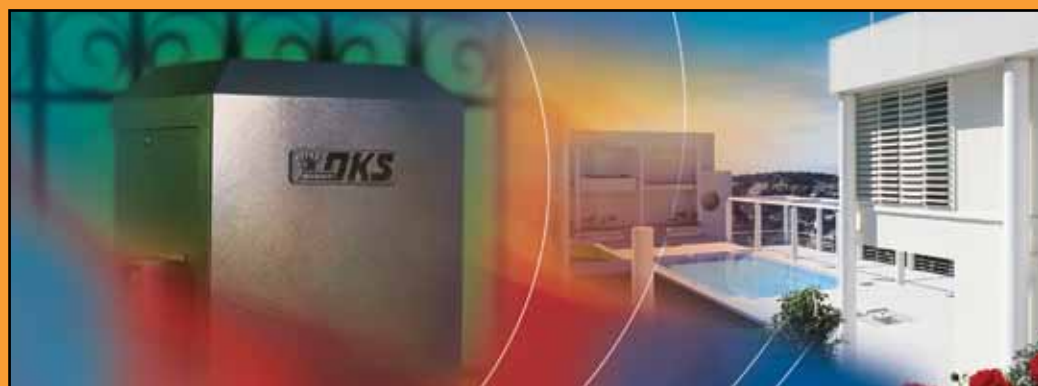



9150 VEHICULAR SLIDE GATE OPERATOR

The DKS 9150 series of slide gate operators offer convenience, reliability and safe operation in a small, compact design. These operators are ideally used in residential, commercial or industrial high-use applications. The innovative fail-safe design of these operators significantly reduces the chance of injury or entrapment and makes these operators the safest slide gate operators in the market today! Designed with versatility in mind, these operators can be configured for front, center or rear drive applications and can be configured for front, center or rear drive applications and can be pad or post mounted.

Advanced Features

- Automatic limit adjustment
- Auto-close timer 1-23 sec
- Selectable stop / reverse loop function
- Timer override feature helps prevent tailgating
- Partial open feature
- Built in On / Off switch
- Built in alarm reset switch
- Two 115 VAC convenience outlets for accessory transformers
- Automatically assumes fail-safe mode when an entrapment condition exists
- Ports for plug-in open and reverse loop detectors. DKS plug-in detectors only
- Gate Tacker reporting output provides operator data to access control system (DKS systems with card access only)

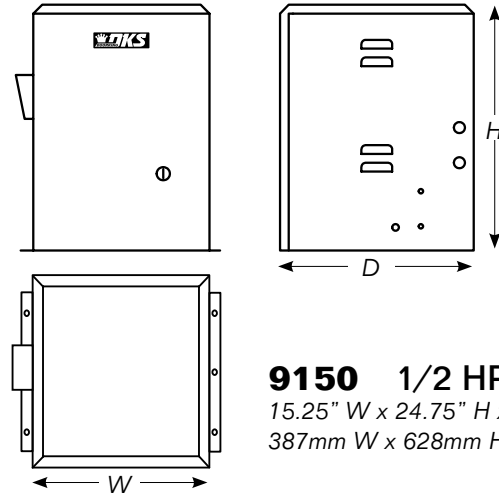

9150 1/2 HP & 1 HP
15.25" W x 24.75" H x 16.75" D
387mm W x 628mm H x 425mm D

9150 1/2 HP Specs

Class of operation	Max Gate Length *	Max Gate Weight *	HP	Power	Convenience Open Package
I, II, III, IV	30 Ft (9.1 m)	1000 Lbs. (453.6 kg)	1/2 HP 60 cycles/hr continuous duty	115 VAC, 60 Hz, 5.4A 208 VAC, 60 Hz, 2.8A** 230 VAC, 60 Hz, 2.7A** 460 VAC, 60 Hz, 1.4A**	Optional

9150 1 HP Specs

Class of operation	Max Gate Length *	Max Gate Weight *	HP	Power	Convenience Open Package
I, II, III, IV	45 Ft (13.7 m)	1500 Lbs. (680.3 kg)	1HP 60 cycles/hr continuous duty	115 VAC, 60 Hz, 7.0A 208 VAC, 60 Hz, 5.0A** 230 VAC, 60 Hz, 3.5A** 460 VAC, 60 Hz, 1.8A**	Optional

* Assumes gate to be in good condition and must be on a level surface.
When combined with convenience open option, 1/2HP max weight is 800 Lbs., and 1300 Lbs. with 1HP.
** These operators use a step-down transformer, to achieve 115 VAC operating voltage.

General Specs

Mechanical

- Primary Reduction: Single cog belt
- Chain: #40
- Speed: Approximately 10 in/sec (254 mm/sec)
- Cover: Steel cover is plated and painted
- Frame: G90 Galvanized steel to prevent rusting

Manual Release

- Fail Safe: Push gate open
- Fail Secure: Keyed release optional

Operator kit

includes chain brackets, hardware, and 20-feet (6 m) of #40 chain

Safety

External obstruction sensing devices must be used with this operator

Options Available

- Nickel plated chain
- Stainless steel chain
- Plug-in loop detectors
- Heater kit for cold environments
- Base plate to post mount (posts not included)
- Fail-secure keyed release

Safety Standards

Complies with the UL 325 and UL 991 safety standards
ETL listed

Operating Temp

10°F to 140°F
-12°C to 62°C
Heater kit recommended for colder environments

Shipping Weight

Approximately 125-185 lbs (56-84 kg)

Warranty

5-year limited factory warranty

Distributed by:

DOOR KING, INC.

120 Glasgow Avenue, Inglewood, California 90301 U.S.A. Tel: 310-645-0023 FAX: 310-641-1586 www.doorking.com

© 2011 All Rights Reserved. Product specifications may change without notice. Rev. 2/11

MEMBER:

